

## Kultúrny kontext (správa)

Identita značky nie je symbolom s nemenným tvarom a jediným významom – je schémou vzťahov. Znázorňuje vzťah zakladajúcich partnerov, ale rovnako aj vzťah právnickej firmy voči svojmu okoliu. Pomlčka vytvára z dvoch mien celok, vymedzuje pomyselný priestor, v ktorom boli hodnoty jasne nastavené a naďalej sa zhodnocujú a uplatňujú v praxi. Z dvoch mien sa stal pojem, ktorý už nepíšeme veľkými písmenami.

Rovnováha je krehká a môže byť kedykoľvek narušená – dôležité je vždy ju vedieť znovu nájsť. Pomlčka je ukazovateľom, je gyroskopickým horizontom, vďaka ktorému sa pilot orientuje a na ktorý sa môže spoľahnúť. Nepredstavuje teda len rovnováhu dvoch „misiek váh“, ale aj rovnováhu voči okolitému prostrediu – spoločnosti.

## Charakter (písmo)

○ "The choice of typeface is the first step in creating a visual identity."

– David Carson

"Type is a beautiful, subtle art; it's like music in print."

– David Jury

○ "Typography is what language looks like. It's a craft that combines art and science, which involves understanding the interaction between letterforms, space, and layout. Great typography has the power to elevate a message, evoke emotion, and create a memorable experience."

– Neville Brody

A good typeface is like an old friend—recognizable, and always there when you need it.

## System (adaptabilita)

○ [...] Is a feature of a system or of a process.

[...] In ecology, adaptability has been described as the ability to cope with unexpected disturbances in the environment.

○ Nová vizuálna identita zobrazuje pôvodné hodnoty súčasným vizuálnym jazykom. Je vytvorená tak, aby dokázala fungovať v súčasných podmienkach rôznorodých médií. Jej dôležitou vlastnosťou je rezponzivnosť – dokáže sa prispôsobovať svojmu okoliu farebnosťou, formou zápisu, priestorom, ktorý zaberá, alebo môže byť v pohybe.

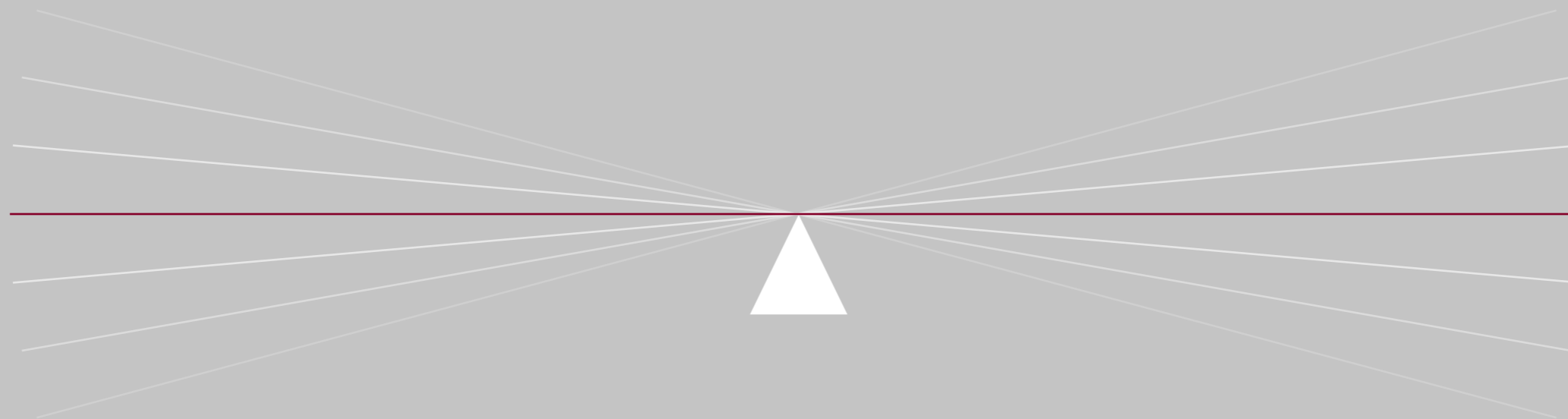

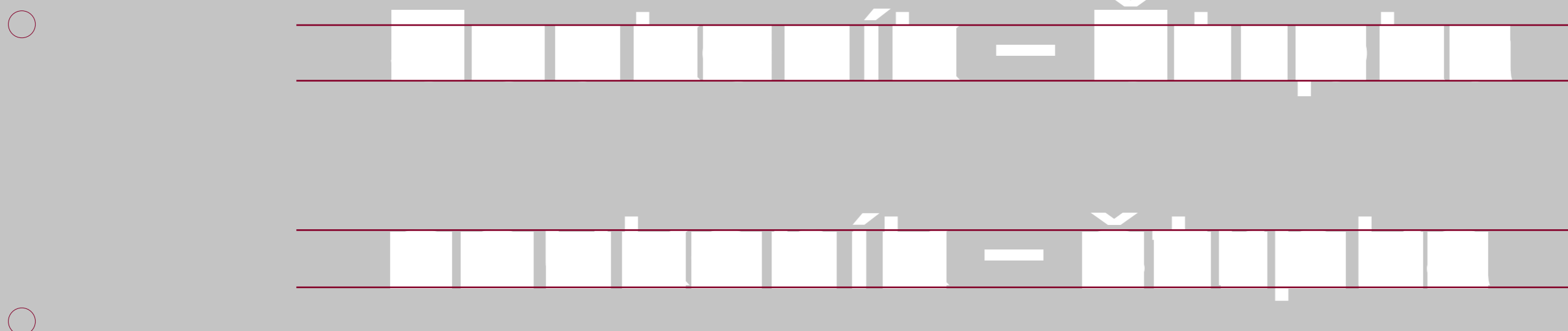

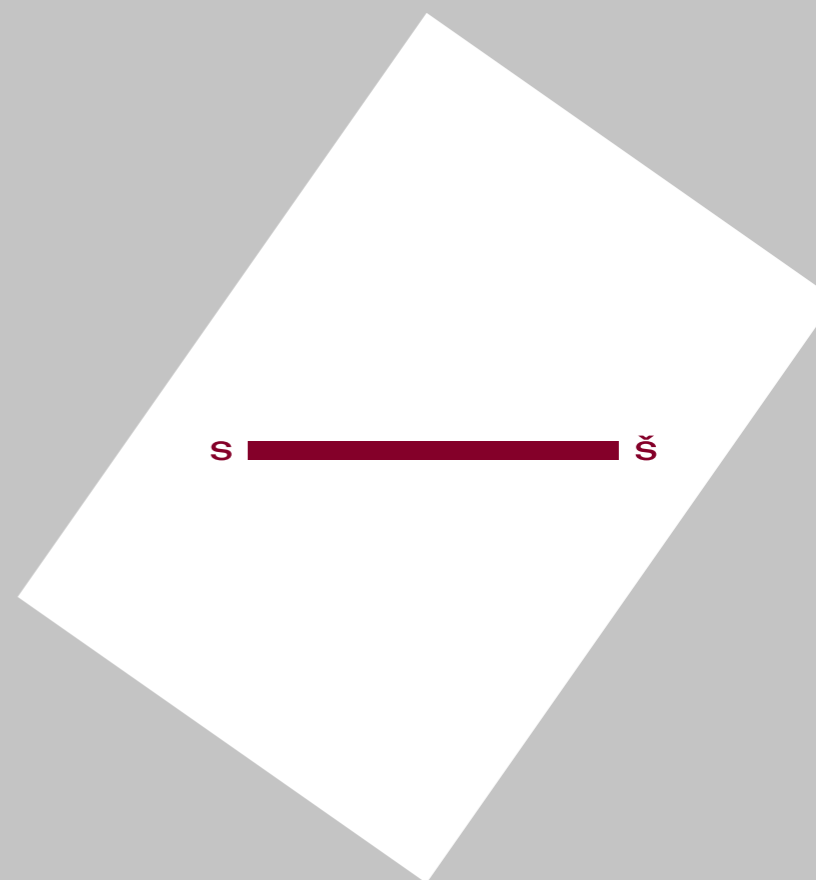
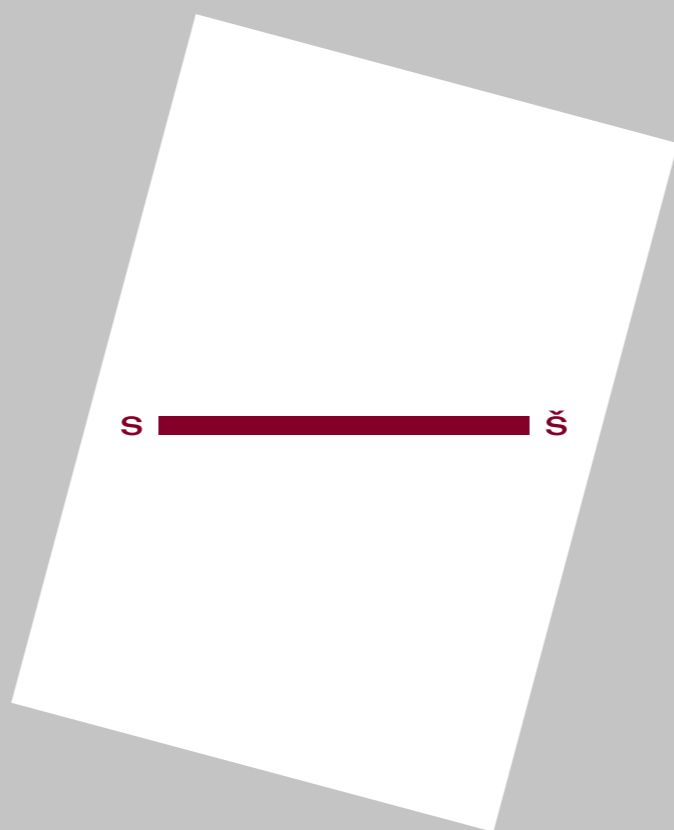
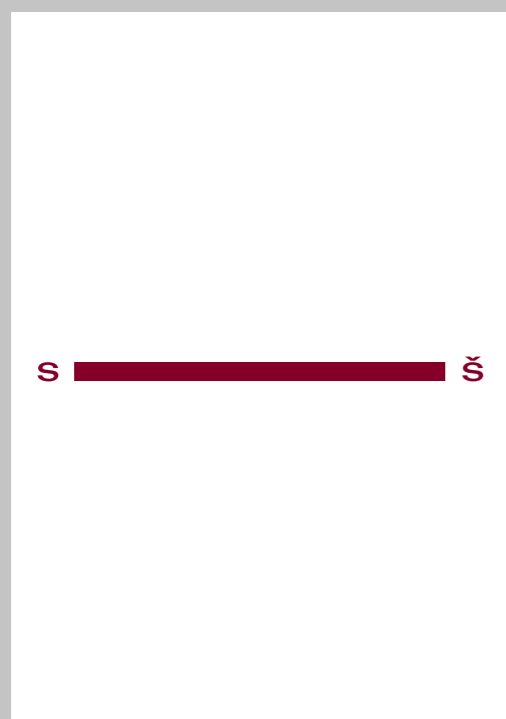

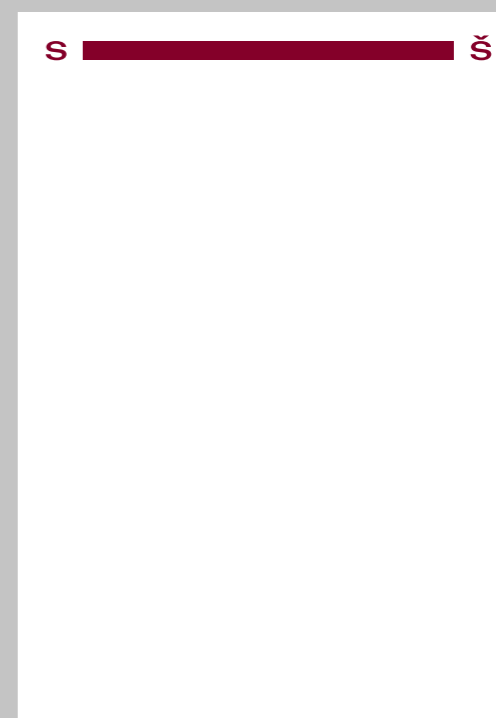
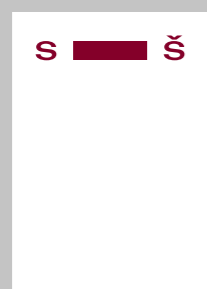

---

Základné východiská a ciele redizajnu	1 – 9
Redizajn	11 – 12
Forma textového zápisu	12
Logo	13 – 25
– všetky platné logá	
– Logá na gride	
– konštrukcia loga	
– variabilita	
– hierarchia verzií	
– zakázané použitie	
– ochranná zóna	
– minimálna veľkosť	
Animácia	26
Farebnosť	27 – 39
– symbolika farieb	
– zloženie farieb	
– farebnosť vs. logo	
Písmo	40 – 41
Priložené súbory	42
Tiráž	43

Původné logo 2009 - 2024

Redizajn 2024/2025

SOUKENÍK-ŠTRPKA 

**soukeník**  **štrpka**

souken  štrpk

souk  štrp

sou  štr

so  št

**S**  **Š**

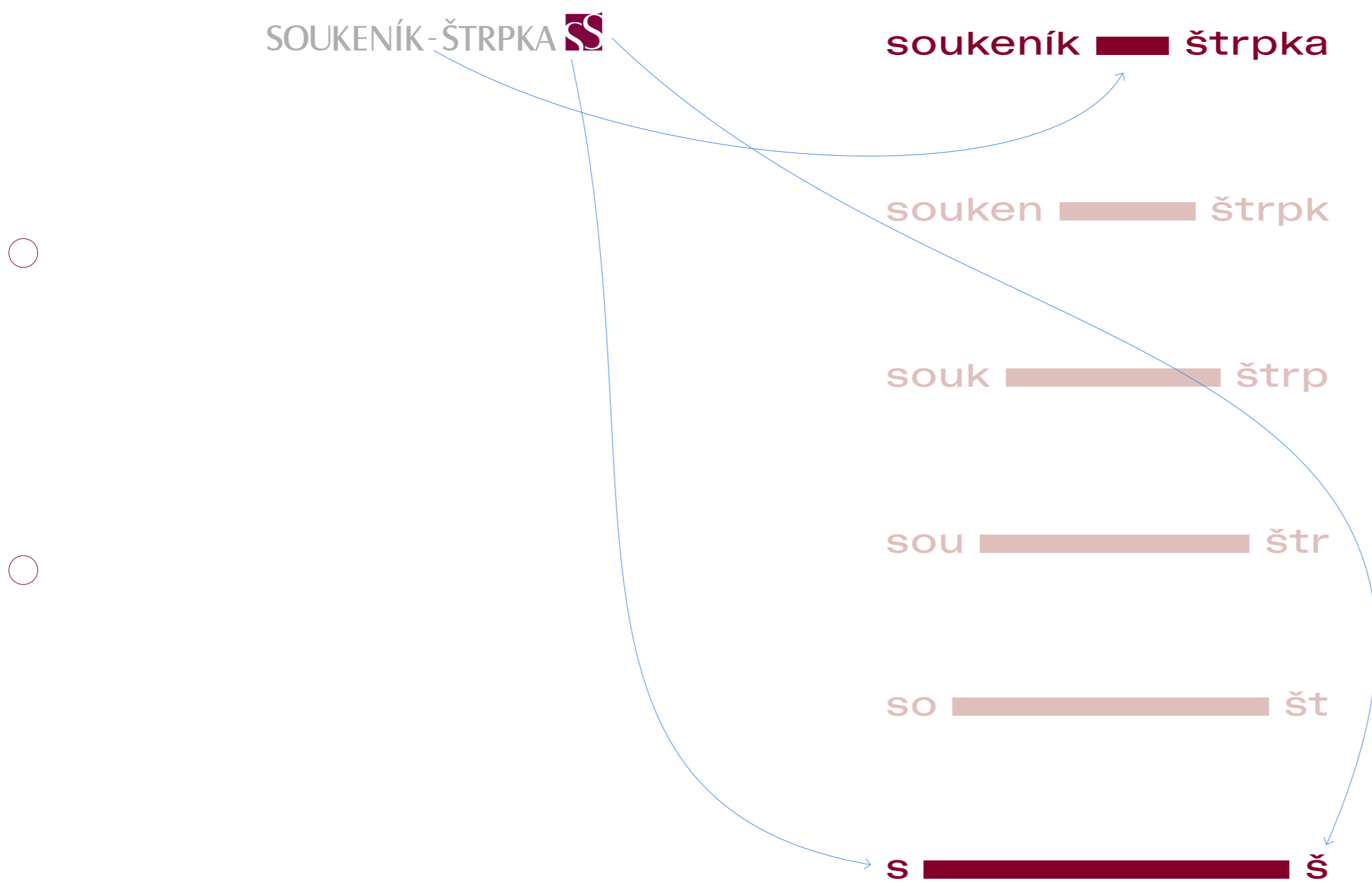

Základné logo "text"

**soukeník**  **štrpka**

Základné logo "kód"

**S**  **Š**

"S", "Š" vs. "s", "š":

Nová vizuálna identita a redizajn loga upravujú aj textový zápis značky soukeník – štrpka. Používa len malé písmená abecedy – minusky. Platí to aj v prípade, že sa názov značky má ocitnúť na začiatku vety. Spôsob akým sa tomu dá vyhnúť, je editorská práca s textom tak, aby veta začínala iným slovom.

Malé písmená sa odporúčajú použiť aj v prípade, ak je názov značky súčasťou textu alebo názvu, ktorý je celý písaný verzálkami, teda veľkými písmenami.

"-" vs. "-":

Ďalším pravidlom je správne použitie spojovacieho znaku v názve, "-" pomlčky, ktorá spája dve slová. Je dôležité, nezamieňať ju za rozdelovník "-", ten je kratší a jeho použitie má iný význam aj zápis.

správny zápis:

(soukeník) (medzera) (pomlčka) (medzera) (štrpka)

"soukeník – štrpka"

~~Sokeník – Štrpka~~

~~soukeník - štrpka~~

~~soukeník-štrpka~~

nepoužívať začiatkové písmená veľké  
nepoužívať spojovník namiesto pomlčky  
nepoužívať pomlčku bez medzier

soukeník – štrpka

medzera pomlčka medzera

Primárne logo "text"

soukeník  štrpka

Primárne logo "kód"  
a jeho variácie

s  š

Sekundárne logo a jeho  
variácie

soukeník  
  
štrpka

s  š

soukeník  
  
štrpka

s  š

soukeník  
  
štrpka

s  š

soukeník  
  
štrpka

s  š

soukeník  
  
štrpka



soukeník ■■■ štrpka



**soukeník**

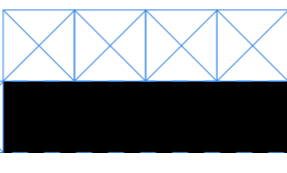

**štrpka**

soukeník  štrpka

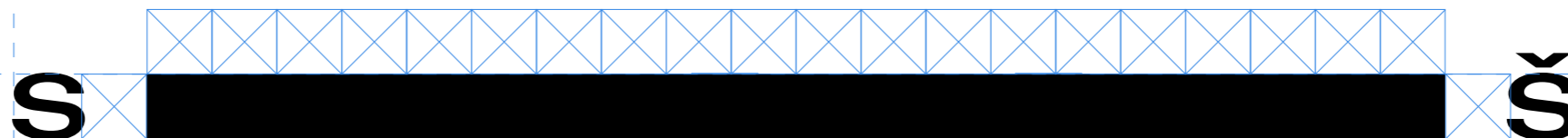

**soukeník**

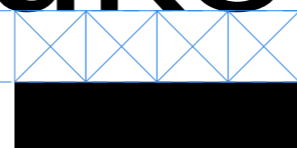

**štrpka**

prímárne logo

sekundárne logo

logo "text"

soukeník ■ štrpka

souken ■ štrpk

souk ■ štrp

sou ■ štr

so ■ št

logo "kód"  
- maximálna šírka

**s ■ š**

**s ■ š**

**s ■ š**

logo "kód"  
- minimálna šírka

**s ■ š**

**soukeník**  
**štrpka**

**soukeník**  
**štrpka**

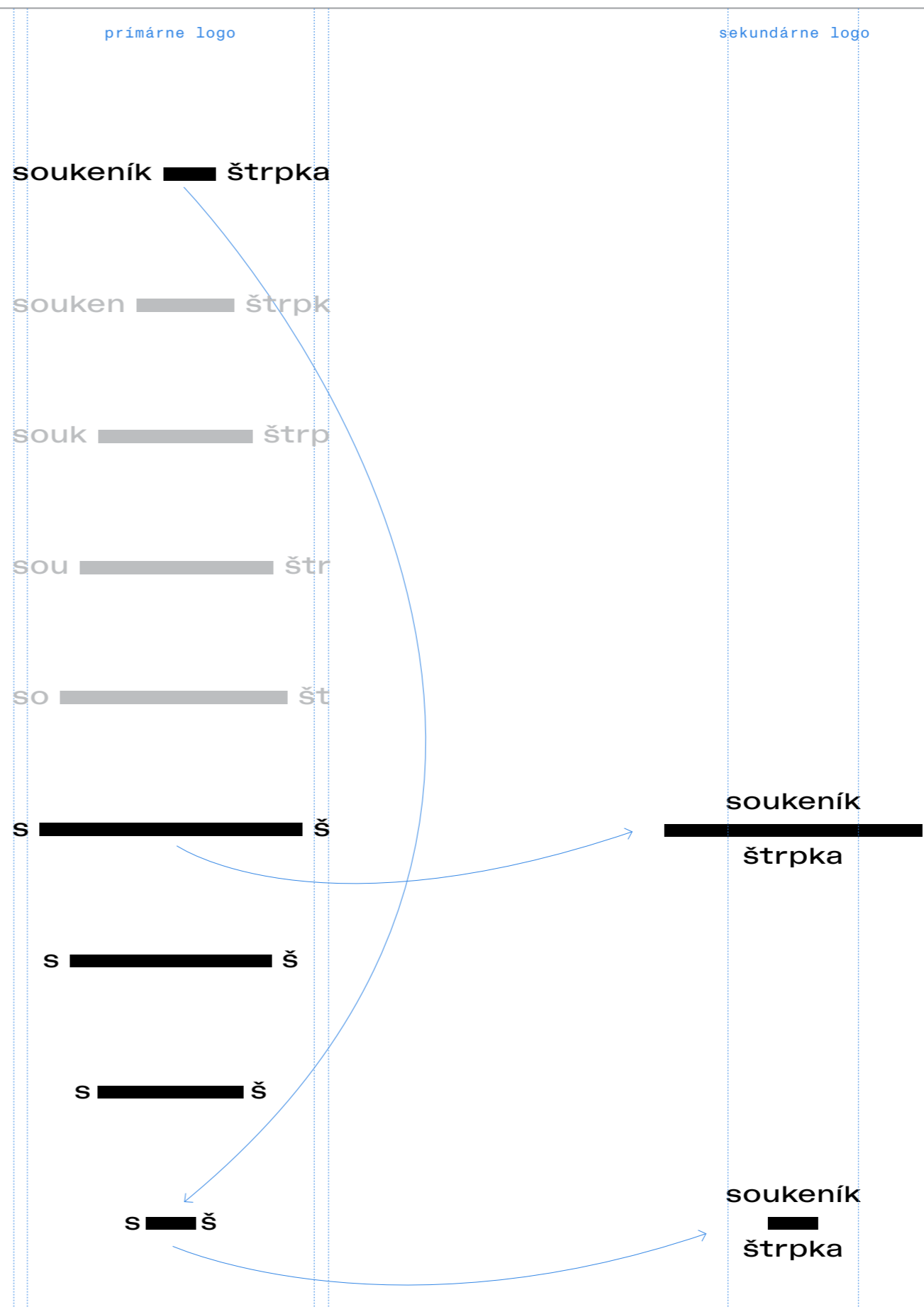

soukeník ■ štrpka



4 x ☒

soukeník  
■  
štrpka



8 x ☒

soukeník  
■■■■■■■■  
štrpka



12 x ☒

soukeník  
■■■■■■■■■■■■  
štrpka



16 x ☒

soukeník  
■■■■■■■■■■■■■■■■  
štrpka



20 x ☒

soukeník  
■■■■■■■■■■■■■■■■■■■■  
štrpka

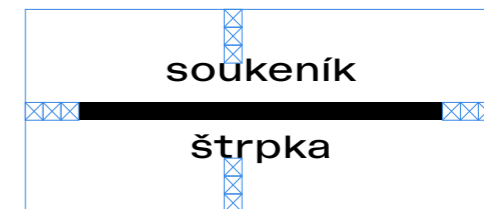
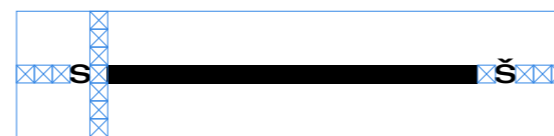
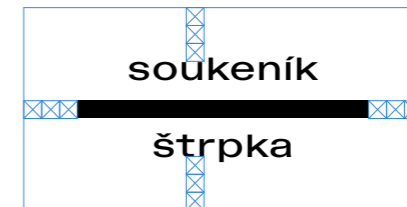
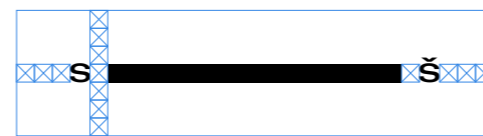
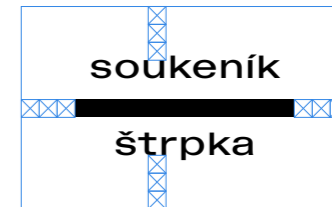
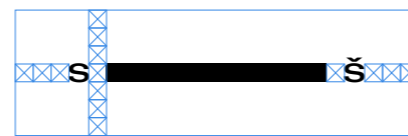
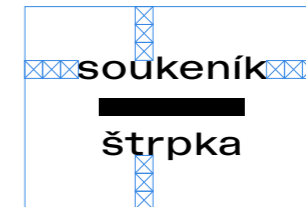
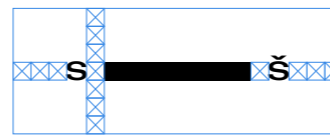
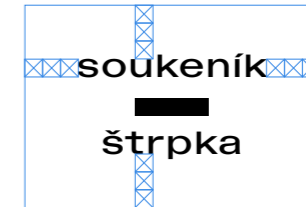
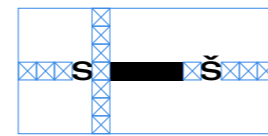
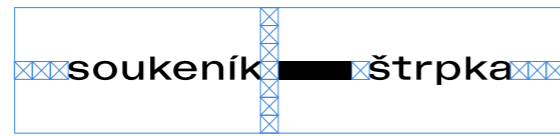

soukeník ■ štrpka

34 mm

s ■ š

11 mm

s ■ š

16,5 mm

s ■ š

22 mm

s ■ š

27,5 mm

s ■ š

33 mm

soukeník

■

štrpka

11 mm

soukeník

■

štrpka

11 mm

soukeník

■

štrpka

12,6 mm

soukeník

■

štrpka

17,1 mm

soukeník

■

štrpka

20,9 mm

**soukeník**  **štrpka**

V žiadnej z verzií loga sa nesmie používať "pomlčka dlhšia ako je v predpísaných možnostiach na strane XXX

**s**  **š**

V žiadnej z verzií loga sa nesmie používať "pomlčka kratšia ako je v predpísaných možnostiach na strane 22 tohoto dizajn manuálu

**soukeník**  
  
**štrpka**

V žiadnej z verzií loga sa nesmie kompozícia jednotlivých prvkov meniť inak ako je predpísané na strane 22 tohoto dizajn manuálu

  
**soukeník**  **štrpka**

Žiadna z verzií loga sa nesmie používať na podklade, ktorý má výraznú štruktúru a bráni jasnej čitateľnosti a rozpoznateľnosti loga

**s**  **š**

Žiadna z verzií loga sa nesmie používať v statickej podobe naklonená

**soukeník**  
  
**štrpka**

Žiadna z verzií loga sa nesmie deformovať – teda meniť rozmer neproporčne

**soukeník**  **štrpka**

Žiadna z verzií loga sa nesmie používať vo verzii s obvodovou linkou

**s**  **š**

V žiadnej z verzií loga sa nesmie "pomlčka" rotovať

**soukeník**  
  
**štrpka**

V žiadnej z verzií loga sa nesmie meniť hrúbka "pomlčky" inak ako je v predpísaných možnostiach na strane 22 tohoto dizajn manuálu

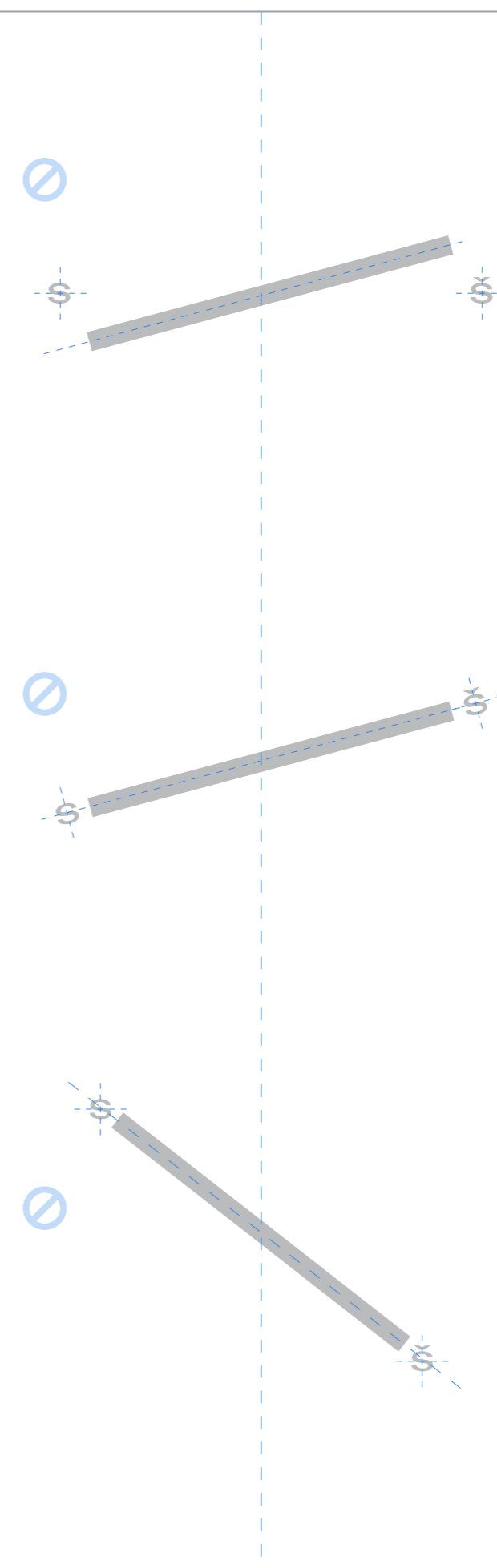
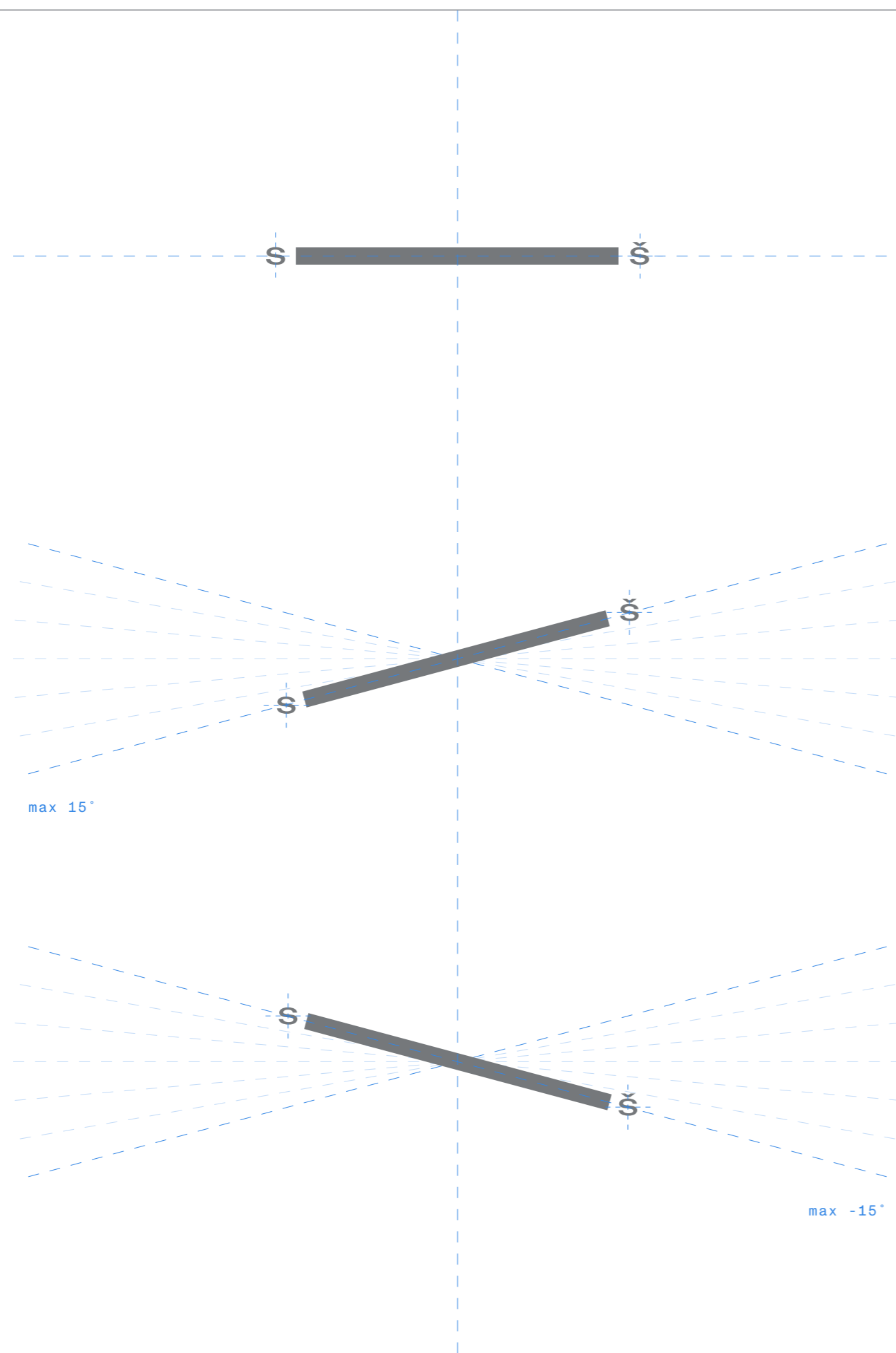

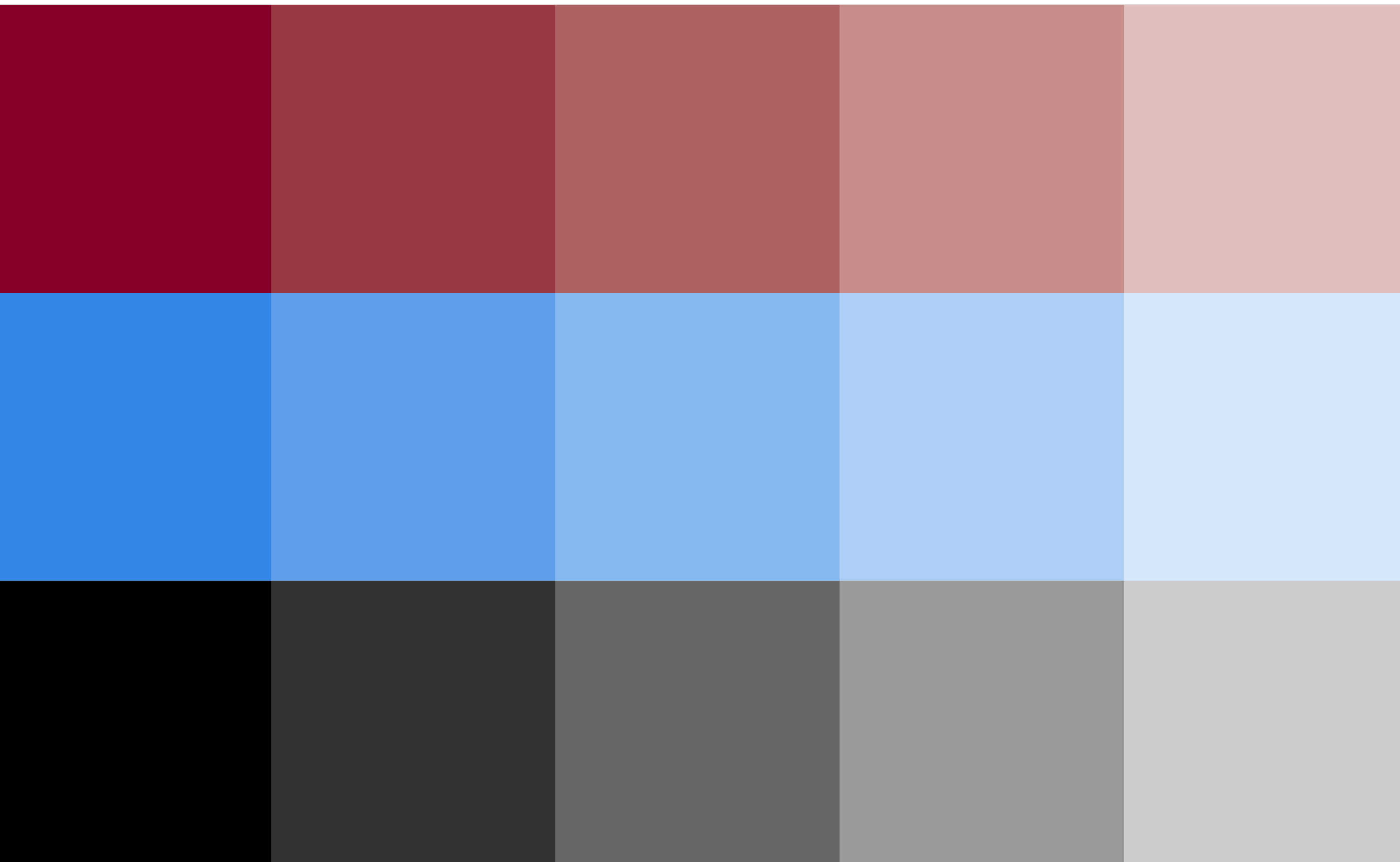

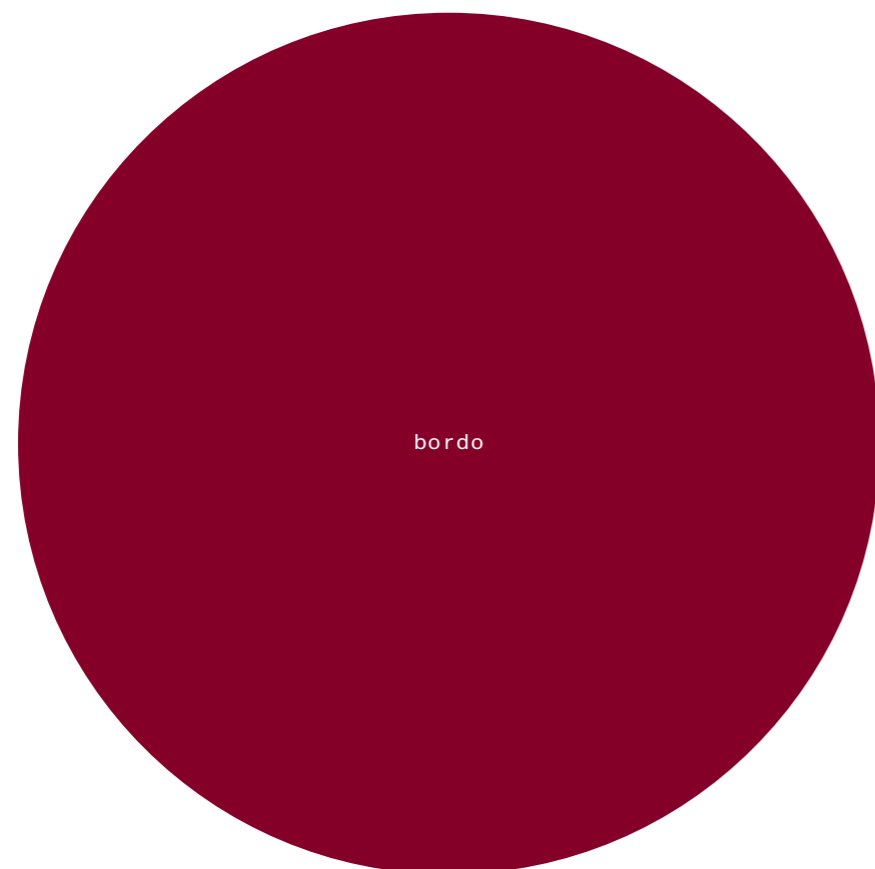

bordo

Bordo: farba, ktorá je súčasťou značky soukenik – štrpka od úplného začiatku. Je základnou farbou identity a objavuje sa v menšej miere na prioritných miestach. Okrem vína sa význam slova spáj aj s letectvom a námorníctvom a znamená "on board".

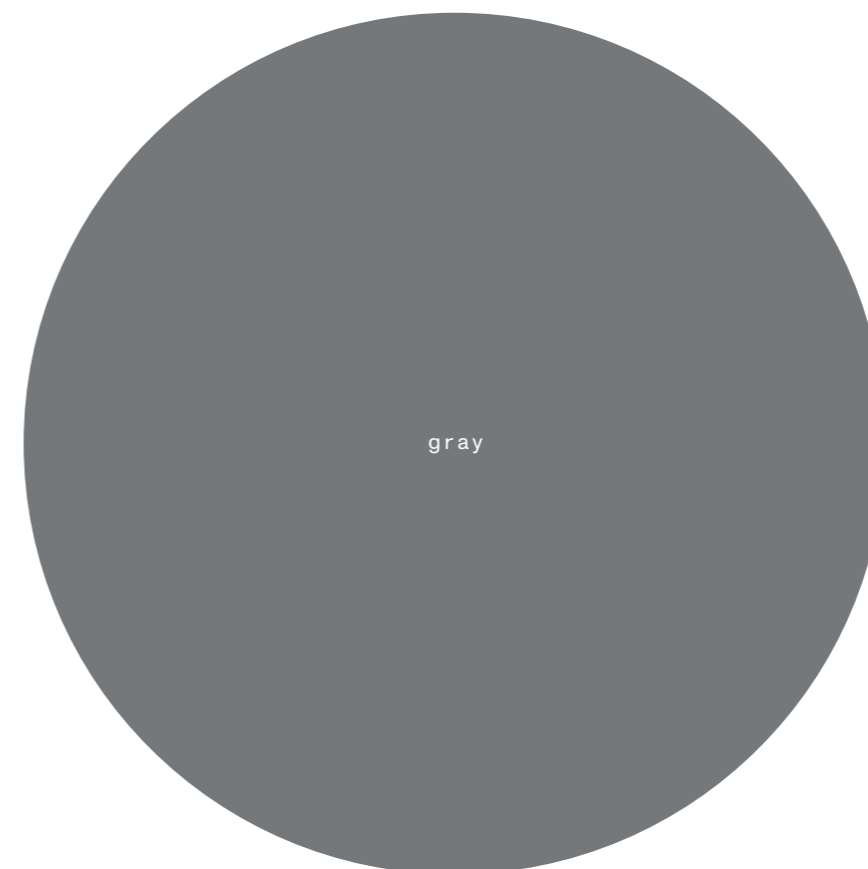

gray

Gray: okrem čiernej farby, ktorá je z funkčného hľadiska prirodzene súčasťou identity, doľna škálu aj jej svetlejší odtieň – šedá. Vytvára optickú hĺbku a tvorí most medzi striebornou a čiernou.

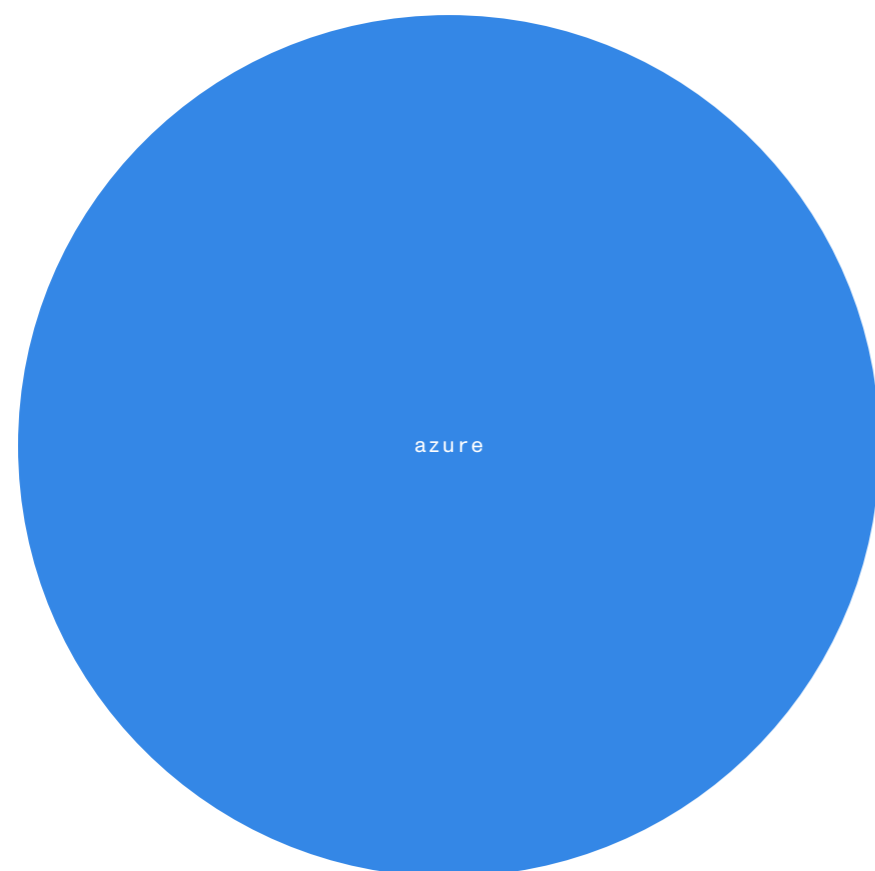

azure

Azure: modrá farba – nazvaná podľa čistej oblohy, je novou doplnkovou farbou. Svojou vzdušnosťou dpíňa zemitú základnú farbu. Objavuje sa len výnimočne, rovnako ako jasná obloha a ako kontrapunkt k primárnej bordovej a funkčnej šedej.

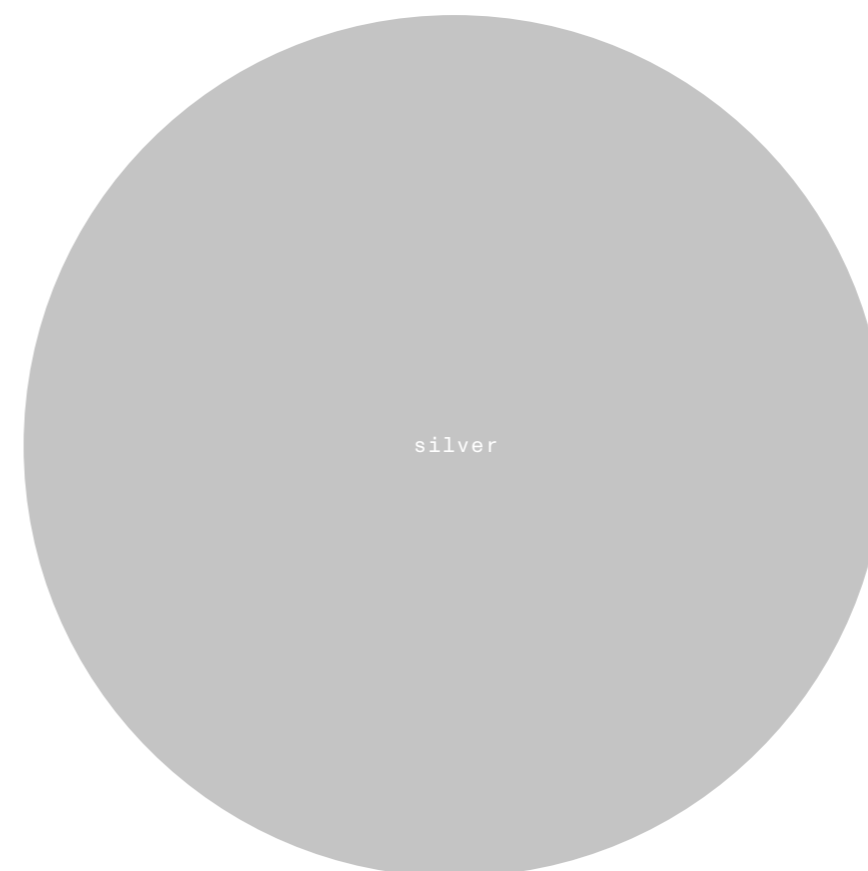

silver

Silver: podobne ako Bordo aj strieborná, je základným piliérom identity od začiatku fungovania advokátskej kancelárie. Symbolicky je so značkou spätá svojou schopnosťou reagovať na okolie. Je symbolom reflexie. Nie je to statická homogénna plocha ale zrkadlo ktoré živo reaguje na svoje okolie.

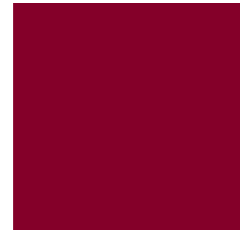

Bordo

R 132  
G 0  
B 41

# 840028

C 9 %  
M 100 %  
Y 64 %  
K 48 %

Pantone 202



Azure

R 52  
G 135  
B 230

# 3487e6

C 75  
M 41  
Y 0  
B 0

Pantone 279

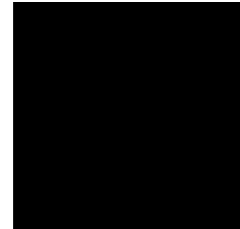

Black

R 0  
G 0  
B 0

# 000000

C 0  
M 0  
Y 0  
B 100

Pantone Black 3 C



Gray

R 117  
G 120  
B 123

# 75787b

C 0  
M 0  
Y 0  
B 75

Pantone Cool Gray 9



Silver

R 196  
G 196  
B 196

# c4c4c4

C 0  
M 0  
Y 0  
B 35Pantone Cool Gray 5 C  
Pantone SILVER-10077 C

Základná farebná varianta

**soukeník**  **štrpka**

Základná farebná varianta

**soukeník**  **štrpka**

**soukeník**  **štrpka**

**soukeník**  **štrpka**

**soukeník**  **štrpka**

**soukeník**  **štrpka**

**soukeník**  **štrpka**

**soukeník**  **štrpka**

**soukeník**  **štrpka**

**soukeník**  **štrpka**

soukeník  štrpka

s  š

soukeník  štrpka

s  š

soukeník  štrpka

s  š

soukeník  štrpka

s  š

soukeník  štrpka

s  š

soukeník  štrpka

s  š





soukeník ■■■ štrpka

s ■■■■■ š



# ABC Pelikan Regular

# ABC Pelikan Medium

# ABC Pelikan Bold

# *ABC Pelikan Regular Italic*

# *ABC Pelikan Medium Italic*

# *ABC Pelikan Bold Italic*

Exceștiur am, autem nobit  
eveni nesti is cum aut quaectur  
as id quidell andaecus atium  
in nempore deruptatat omniae  
nonsecu scimet que maxim  
restia il im ipitas et erem.  
Nametursundaep repedis as  
nullaborenia doluptiatem et est  
millicime re nonse eum fugias  
cus enias ea volorum esti bea  
sunt fugit et quidis que nonecte  
atis ditiame volesec tiorpos  
quantiisquia elit, quos ditas  
vendi ommoluptum reperum  
quatemqui blatiossinus milique  
inulluptat odit, cus dictatur? Bo.  
To endicto is magnimi llictorum  
aut ut aut asimetur? Tae odi sim  
auda consequia quiam id quo  
coremqui nemoditatur sequi to  
odit, cusaes ullaborposa sundis  
sunt exernat atur, officaecum  
sum qui dolupta nihit qui vollab  
imernatum es a plam fugit  
delest aut ima qui dedit, ut pro  
blab ium idipitam, quibus atur  
am que ditatectiae. Ut om-  
modisquae que ilitate nos sam  
et modis di reperibus non cone  
exerro quibea auda voluptis  
exero ipsantiscit mil magnimi  
lilitis dios re vit, temquid uciatis  
maios exerrum idelesequam fu-  
giae velit aut odiciisitiis et quis

Exceștiur am, autem nobit  
eveni nesti is cum aut quaectur  
as id quidell andaecus atium in  
nempore deruptatat omniae  
nonsecu scimet que maxim res-  
tia il im ipitas et erem. Nametur  
sundaep repedis as nullabore-  
nia doluptiatem et est millicime  
re nonse eum fugias cus enias  
ea volorum esti bea sunt fu-  
git et quidis que nonecte atis  
ditiame volesec tiorpos quanti-  
isquia elit, quos ditas vendi om-  
moluptum reperum quatemqui  
blatiossinus milique inulluptat  
odit, cus dictatur? Bo. To en-  
dicto is magnimi llictorum aut  
ut aut asimetur? Tae odi sim  
auda consequia quiam id quo  
coremqui nemoditatur sequi to  
odit, cusaes ullaborposa sundis  
sunt exernat atur, officaecum  
sum qui dolupta nihit qui vollab  
imernatum es a plam fugit  
delest aut ima qui dedit, ut  
pro blab ium idipitam, quibus  
atur am que ditatectiae. Ut om-  
modisquae que ilitate nos sam  
et modis di reperibus non cone  
exerro quibea auda voluptis  
exero ipsantiscit mil magnimi  
lilitis dios re vit, temquid uciatis  
maios exerrum idelesequam fu-  
giae velit aut odiciisitiis et quis

Exceștiur am, autem nobit  
eveni nesti is cum aut quaectur  
as id quidell andaecus atium  
in nempore deruptatat omniae  
nonsecu scimet que maxim  
restia il im ipitas et erem.  
Nametursundaep repedis as  
nullaborenia doluptiatem et  
est millicime re nonse eum  
fugias cus enias ea volorum  
esti bea sunt fugit et quidis  
que nonecte atis ditiame  
volesec tiorpos quantiisquia  
elit, quos ditas vendi ommo-  
luptum reperum quatemqui  
blatiossinus milique inulluptat  
odit, cus dictatur? Bo. To en-  
dicto is magnimi llictorum aut  
ut aut asimetur? Tae odi sim  
auda consequia quiam id quo  
coremqui nemoditatur sequi to  
odit, cusaes ullaborposa sun-  
dis sunt exernat atur, officae-  
cum sum qui dolupta nihit qui  
vollab imernatum es a plam  
fugit delest aut ima qui dedit,  
ut pro blab ium idipitam, qui-  
bus atur am que ditatectiae. Ut  
ommodisquae que ilitate nos  
sam et modis di reperibus non  
cone exerro quibea auda volup-  
tis exero ipsantiscit mil mag-  
nimi lilitis dios re vit, temquid  
uciatis maios exerrum idelese-

*Exceștiur am, autem nobit  
eveni nesti is cum aut quaectur  
as id quidell andaecus atium  
in nempore deruptatat omniae  
nonsecu scimet que maxim  
restia il im ipitas et erem.  
Nametursundaep repedis as  
nullaborenia doluptiatem et est  
millicime re nonse eum fugias  
cus enias ea volorum esti bea  
sunt fugit et quidis que nonecte  
atis ditiame volesec tiorpos  
quantiisquia elit, quos ditas  
vendi ommoluptum reperum  
quatemqui blatiossinus milique  
inulluptat odit, cus dictatur? Bo.  
To endicto is magnimi llictorum  
aut ut aut asimetur? Tae odi sim  
auda consequia quiam id quo  
coremqui nemoditatur sequi to  
odit, cusaes ullaborposa sundis  
sunt exernat atur, officaecum  
sum qui dolupta nihit qui vollab  
imernatum es a plam fugit  
delest aut ima qui dedit, ut pro  
blab ium idipitam, quibus atur  
am que ditatectiae. Ut om-  
modisquae que ilitate nos sam  
et modis di reperibus non cone  
exerro quibea auda voluptis  
exero ipsantiscit mil magnimi  
lilitis dios re vit, temquid uciatis  
maios exerrum idelesequam fu-  
giae velit aut odiciisitiis et quis*

*Exceștiur am, autem nobit  
eveni nesti is cum aut quaectur  
as id quidell andaecus atium in  
nempore deruptatat omniae  
nonsecu scimet que maxim res-  
tia il im ipitas et erem. Nametur  
sundaep repedis as nullabore-  
nia doluptiatem et est millicime  
re nonse eum fugias cus enias  
ea volorum esti bea sunt fugit  
et quidis que nonecte atis di-  
tiame volesec tiorpos quantiis-  
quia elit, quos ditas vendi om-  
moluptum reperum quatemqui  
blatiossinus milique inulluptat  
odit, cus dictatur? Bo. To en-  
dicto is magnimi llictorum aut  
ut aut asimetur? Tae odi sim  
auda consequia quiam id quo  
coremqui nemoditatur sequi to  
odit, cusaes ullaborposa sundis  
sunt exernat atur, officaecum  
sum qui dolupta nihit qui vollab  
imernatum es a plam fugit  
delest aut ima qui dedit, ut  
pro blab ium idipitam, quibus  
atur am que ditatectiae. Ut om-  
modisquae que ilitate nos sam  
et modis di reperibus non cone  
exerro quibea auda voluptis  
exero ipsantiscit mil magnimi  
lilitis dios re vit, temquid uciatis  
maios exerrum idelesequam fu-  
giae velit aut odiciisitiis et quis*

*Exceștiur am, autem nobit  
eveni nesti is cum aut quaectur  
as id quidell andaecus atium  
in nempore deruptatat omniae  
nonsecu scimet que maxim  
restia il im ipitas et erem.  
Nametursundaep repedis as  
nullaborenia doluptiatem et  
est millicime re nonse eum fu-  
gias cus enias ea volorum esti  
bea sunt fugit et quidis que  
nonecte atis ditiame volesec  
tiorpos quantiisquia elit, quos  
ditas vendi ommoluptum  
reperum quatemqui blatiossi-  
nus milique inulluptat odit,  
cus dictatur? Bo. To endicto is  
magnimi llictorum aut ut aut  
asimetur? Tae odi sim auda  
consequia quiam id quo corem-  
qui nemoditatur sequi to odit,  
cusaes ullaborposa sundis  
sunt exernat atur, officaecum  
sum qui dolupta nihit qui vollab  
imernatum es a plam fugit de-  
lest aut ima qui dedit, ut pro  
blab ium idipitam, quibus atur  
am que ditatectiae. Ut om-  
modisquae que ilitate nos sam  
et modis di reperibus non cone  
exerro quibea auda voluptis  
exero ipsantiscit mil magnimi  
lilitis dios re vit, temquid ucia-  
tis maios exerrum idelesequam*

**soukeník [redacted] štrpka**

[AKSS\\_LOGO\\_text\\_zakladne\\_black.pdf](#)  
[AKSS\\_LOGO\\_text\\_zakladne\\_bordo.pdf](#)

**s [redacted] š**

[AKSS\\_LOGO\\_kod\\_4\\_black.pdf](#)  
[AKSS\\_LOGO\\_kod\\_4\\_bordo.pdf](#)

**soukeník  
[redacted]  
štrpka**

[AKSS\\_LOGO\\_sek\\_4\\_black.pdf](#)  
[AKSS\\_LOGO\\_sek\\_4\\_bordo.pdf](#)

**s [redacted] š**

[AKSS\\_LOGO\\_kod\\_8\\_black.pdf](#)  
[AKSS\\_LOGO\\_kod\\_8\\_bordo.pdf](#)

**soukeník  
[redacted]  
štrpka**

[AKSS\\_LOGO\\_sek\\_8\\_black.pdf](#)  
[AKSS\\_LOGO\\_sek\\_8\\_bordo.pdf](#)

**s [redacted] š**

[AKSS\\_LOGO\\_kod\\_12\\_black.pdf](#)  
[AKSS\\_LOGO\\_kod\\_12\\_bordo.pdf](#)

**soukeník  
[redacted]  
štrpka**

[AKSS\\_LOGO\\_sek\\_12\\_black.pdf](#)  
[AKSS\\_LOGO\\_sek\\_12\\_bordo.pdf](#)

**s [redacted] š**

[AKSS\\_LOGO\\_kod\\_16\\_black.pdf](#)  
[AKSS\\_LOGO\\_kod\\_16\\_bordo.pdf](#)

**soukeník  
[redacted]  
štrpka**

[AKSS\\_LOGO\\_sek\\_16\\_black.pdf](#)  
[AKSS\\_LOGO\\_sek\\_16\\_bordo.pdf](#)

**s [redacted] š**

[AKSS\\_LOGO\\_kod\\_20\\_black.pdf](#)  
[AKSS\\_LOGO\\_kod\\_20\\_bordo.pdf](#)

**soukeník  
[redacted]  
štrpka**

[AKSS\\_LOGO\\_sek\\_20\\_black.pdf](#)  
[AKSS\\_LOGO\\_sek\\_20\\_bordo.pdf](#)



Redizajn vizuálnej identity:  
Studio Ľubica Segečová s.r.o.  
Ľubica Segečová  
Róbert Púček

Všetky práva sú upravené autorskou a licenčnou zmluvou.

© 2025

soukeník ■ štrpka